

# PRO Series

## Timer and Timer/Counter

### Precise control.

**vanSCO**'s **PRO Series Timers and Timer/Counters** are multi-purpose, time-based, microprocessor driven electronic control systems. Both models can be used in any process that requires precisely timed actuation of electronic output devices, such as case sealing, palletizing, labeling, cartoning, bag making, and many other applications.

### **vanSCO**'s **PRO Series Timer and Timer/Counter:**

#### **PRO Series Timer**

Two independently programmable channels, each with four output (glue) events and four non-output (skip) events

Selectable stitch option for each channel

Selectable latch-on and repeat-cycle options for each channel

Three time ranges: 0-0.999 seconds, 0-9.99 seconds, and 0-99.9 seconds

Selectable input source for each channel

#### **PRO Series Timer/Counter**

A programmable timer and integrated six-mode counter

Four output (glue) events and four non-output (skip) events

#### **Both PRO Series Models**

Specifically developed to control output from valves used in adhesive application systems

Have the ability to count actuations of an output device and take various actions based on that count

Four program storage capacity in non-volatile memory

No battery back-up required

Sixteen character by two line LCD display

On-screen status line

Input and output test routines

Program security access code

115 VAC and 24 VDC outputs

Plug-in connections



# PRO Series Timer and Timer/Counter

All controls and displays, except the power switch, are mounted inside a rugged enclosure with a protective cover. This also prevents unauthorized adjustment and tampering.

The operator interface includes a sealed membrane switch control panel and a sixteen character, two line display window. Using direction buttons on the control panel, the display window is moved to view program variables such as event times. When the desired information is displayed, new data can easily be entered using the data keys. The **PRO SERIES** controls can store and retrieve four different programs.

The **PRO SERIES TIMER** has two independent, separately programmable Channels, A and B, each with its own output port. Each channel can be operated individually, using its own trigger input device or can be operated in tandem, with both channels using the same input. Each channel has eight programmable time periods called events - four are OUTPUT (GLUE)

EVENTS and four are NON-OUTPUT (SKIP) EVENTS. In addition, each channel includes a selectable stitch option for GLUE EVENTS, three time ranges, and both single cycle and repeat cycle operation. Each channel can be programmed to operate with or without latch-on.

The **PRO SERIES TIMER/COUNTER** includes a six mode counter subsystem with external reset. Channel A is independently programmable and incorporates all the features described above. Channel B output depends on the count mode selected and cannot be independently programmed. For count modes (such as the totalizing mode) which do not require an output, Channel B "tracks" Channel A: activates when the first Channel A output events become active and deactivates when the last Channel A output event deactivates. Other count modes will cause Channel B to "toggle" (change its output state) or "pulse" (turn on for an operator-set time period) when programmed counts are reached.

## Technical Characteristics

<b>PRO Series Specifications</b>			
<b>Inputs:</b>	<b>Power:</b> 115VAC, 50 or 60 Hz <b>Sensor:</b> 12VDC current sinking (open-collector)		
<b>Outputs:</b>	<b>AC Output:</b> 115VAC, 2.0 amp <b>DC Output:</b> 24VDC, 1.5 amp <b>Power for sensor(s):</b> 12VDC, 0.250 amp    (220 VAC not available)		
<b>Dimensions:</b>	<b>Enclosure:</b> 10" wide x 12" wide x 5" deep (254mm x 305mm x 127mm) <b>Mounting Holes (6):</b> 4" x 10", 1/4-20 THD (120mm x 254mm)		
<b>Weight:</b>	Approximately 12 pounds		
<b>Time Cycle Resolution:</b>	+/- 1 millisecond, all ranges		
<b>Speed:</b>	<b>FAST</b>	<b>MEDIUM</b>	<b>SLOW</b>
<b>Time Ranges:</b>	0.0-0.999 second 0.001 second interval	0.0-9.9 seconds 0.010 second interval	0.0-99.9 seconds 0.100 second interval
<b>Maximum Event Times:</b>	0.999 seconds	9.99 seconds	99.9 seconds
<b>Maximum Time Cycle:</b>	7.99 seconds	1.33 minutes	13.3 minutes
<b>Stitch On/Off Times:</b>	0-0.250 seconds	0-2.50 seconds	0-25.0 seconds

**ISO 9001**  
QUALITY SYSTEMS

For more information visit [www.vansco.com](http://www.vansco.com) or contact us direct.



**VanSco Products**  
2652 Lashbrook Avenue, South El Monte, CA 91733  
Tel: 626.448.7611 / Fax: 626.448.0221  
sales@vansco.com  
www.vansco.com



The PRO SERIES TIMER has two independent, separately programmable Channels, A and B, each with its own output port. Each channel can be operated individually, using its own trigger input device; or, it can be operated in tandem, with both channels using the same input. Each channel has eight programmable time periods called events; Four are OUTPUT (GLUE) EVENTS and four are NON-OUTPUT (SKIP) EVENTS. In addition, each channel includes a selectable stitch option for GLUE EVENTS, three time ranges, and both single cycle and repeat cycle operation. Each channel can be programmed to operate with or without latch-on.

The PRO SERIES TIMER/COUNTER includes a six mode counter subsystem with external reset. Channel A is independently programmable, and incorporates all the features described above. Channel B output depends on the count mode selected, and cannot be independently programmed. For count modes (such as the totalizing mode) which do not require an output, Channel B "tracks" channel A: it activates when the first channel A output events become active, and deactivates when the last channel A output event deactivates. Other count modes will cause channel B to "toggle" (change its output state), or "pulse" (turn on for an operator set time period) when programmed counts are reached.

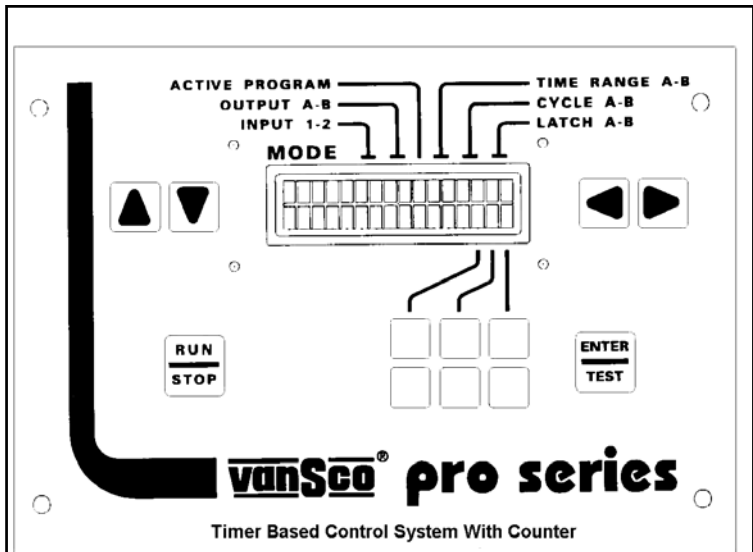

The PRO SERIES TIMERS and TIMER/COUNTERS can store and retrieve four different programs.

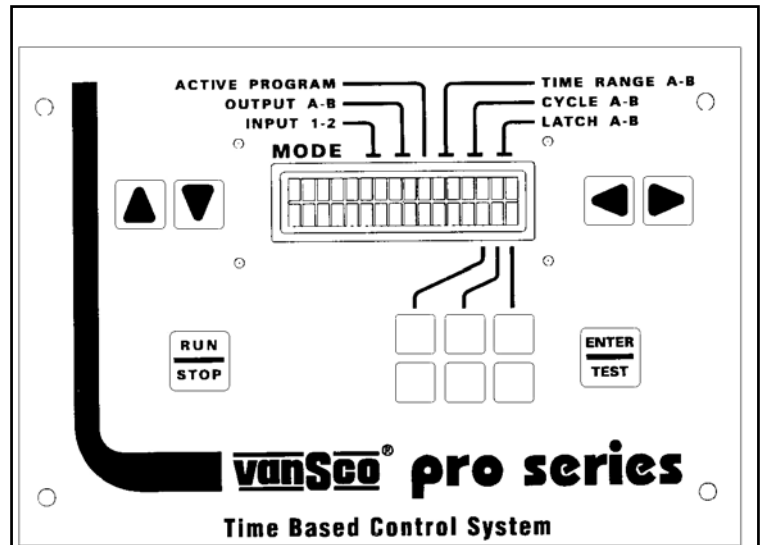

Routines for testing inputs and outputs, configuring for installation and setup, and an access code security system are also provided.

All controls and displays, except the power switch, are mounted inside a rugged enclosure with a protective cover which also prevents unauthorized adjustment and tampering. The operator interface includes a sealed membrane switch control panel and a sixteen character, two line display window. Data entry is "thumb-wheel switch" simple. Using direction buttons on the control panel, the display window is moved to view program variables such as event times. When the desired information is displayed, new data can easily be entered using the data keys if required.

**Engineered to "hook up and run," no confusing hidden set up routines or procedures are required to get the Vansco PRO SERIES TIMERS and TIMER/COUNTERS up and on the job fast! A prewired quick connect for the INPUT DEVICE (and optionally available for the other INPUT and the OUTPUTS) mean trouble free installation and reliable operation.**

# HOW IT WORKS.....

On power-up, the PRO SERIES TIMER or TIMER/COUNTER performs an internal diagnostic and reset routine to initialize and insure that the software is operating properly. On successful completion, the control is ready to operate.

Pressing the STOP/RUN BUTTON will put the control in run mode. When a TRIGGER SIGNAL is received through the selected input for a CHANNEL, a TIME CYCLE for that channel is initiated: The first EVENT with a non-zero time entry is located, then a time counter for the CHANNEL begins to count very precise internally generated CLOCK PULSES, and, if the EVENT is an OUTPUT (GLUE) EVENT, the CHANNEL output is turned on. The running CHANNEL time counter total is constantly compared to the programmed setting for the EVENT. When the numbers are equal, the output is turned off if the EVENT was an OUTPUT EVENT, the next sequential EVENT with a non-zero time entry is located, and the process repeats until the

last EVENT is completed unless the TIME CYCLE is interrupted earlier.

If the repeat cycle option was selected, the channel will continue to repeat the time cycle as long as the trigger signal is active. If the latch-on option was selected, the channel will complete a time cycle, even if the trigger signal was removed.

In the case of the TIMER/COUNTER, the count mode will be updated at the conclusion of channel A time cycle. Output from channel B depends on the count mode selected. For count modes A, B, and D, channel B "tracks" channel A: it activates when the first channel A output event becomes active, and deactivates when the last channel A output event deactivates. For count mode C, the output of channel B "toggles" when the programmed count is reached. The count mode count can be reset to initial conditions at any time, either from the control panel or with an external reset input.

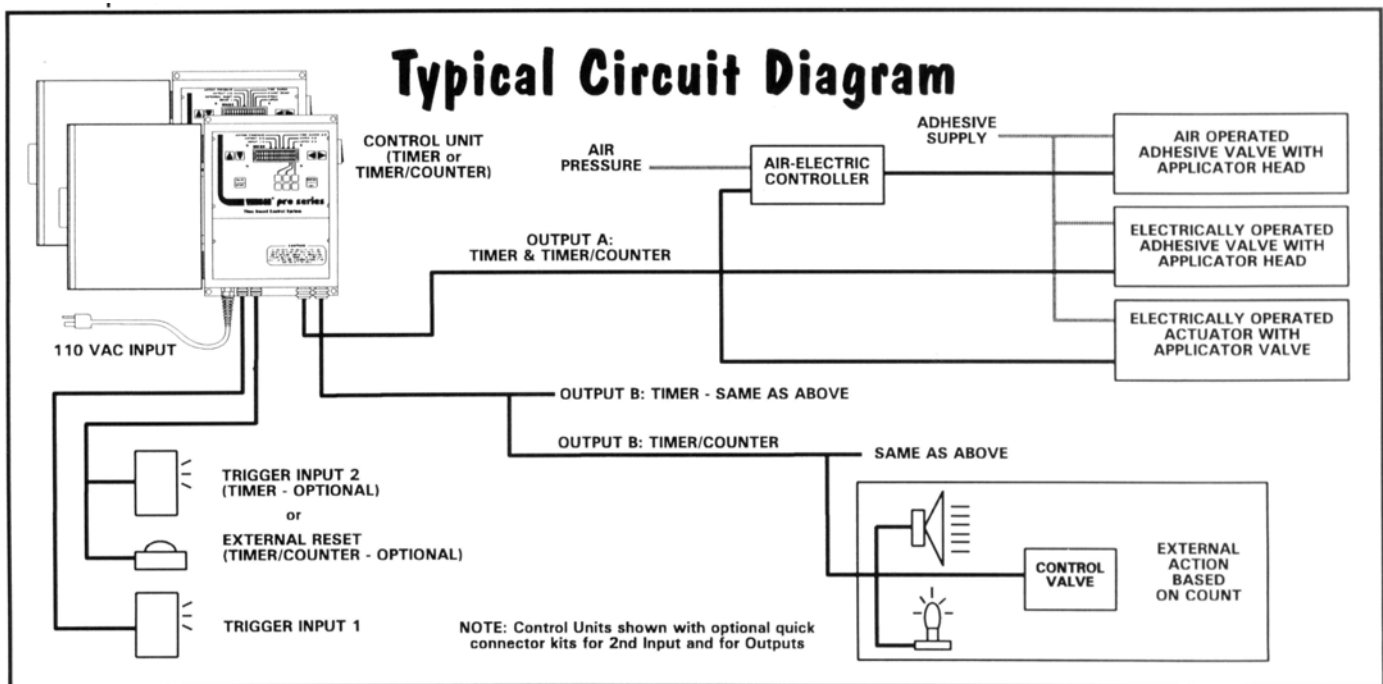

# Specifications...

<b>INPUTS</b>	Power: 115 VAC 50 or 60 Hz Sensor: 12 VDC current sinking (open- collector)
<b>OUTPUTS</b>	AC Output: 115 VAC, 2.0 amp total DC Output: 24 VDC, 1.5 amp total Power for sensor(s): 12 VDC, 0.250 amp total
<b>DIMENSIONS:</b>	Enclosure: 8" wide x 10" high x 4" deep Mounting Holes (4): 7" x 10.625", .250 dia Weight: approximately 11 pounds
<b>PRO SERIES TIMER RESPONSE TIME:</b>	From TRIGGER SIGNAL to start of TIME CYCLE: Less than 1 millisecond
<b>TOTAL RESPONSE TIME:</b>	PRO SERIES TIMER response time plus INPUT DEVICE response time
<b>TIME CYCLE RESOLUTION:</b>	+/- 1 millisecond, all ranges
<b>OUTPUT RESOLUTION:</b>	PRO SERIES TIMER TIME CYCLE resolution plus OUTPUT DEVICE response time
<b>TIME RANGES:</b>	Three: FAST: 0.0 - 0.999 second 0.001 second interval- 9. MEDIUM: 0.0 99 seconds 0.010 second interval SLOW: 0.0 - 99.9 second 0.100 second interval
<b>MAXIMUM EVENT TIMES:</b>	.999 second (FAST range) 9.99 second (MEDIUM range) 99.9 second (SLOW range)
<b>MAXIMUM TIME CYCLE:</b>	7.99 second (FAST range) 1.33 minute (MEDIUM range) 13.3 minute (SLOW range)
<b>SWITCH ON/OFF TIMES:</b>	0-.250 second (FAST range) 0-2.50 second (MEDIUM range) 0-25.0 second (SLOW range)

# Features:

## Pro Series Timer...

- Two independently Programmable Channels
- Four Output (Glue) Events and four Non Output (Skip) Events
- Selectable Stitch Option for each Channel
- Selectable Latch-On and Repeat Cycle Options for each Channel
- Three Time Ranges: 0-.999 Second, 0-9.99 Second, and 0-99.9 Second
- Selectable Input Source for each Channel

## Pro Series Timer/Counter...

- A Programmable Timer and Integrated Counter with Timer and Counter Outputs
- Timer has four Output (Glue) Events and four Non Output (Skip) Events
- **INTEGRATED COUNTER HAS SIX MODES OF OPERATION:**
  - Mode A: Totalizer Mode which counts Channel A cycles.
  - Mode B: Enables the Channel A Output for a Programmed Cycle Count, then disables the Channel A Output for a Programmed Cycle Count, and repeats.
  - Mode C: Same as Mode B, but the Channel B Output toggles at the Enable/Disable Transition.
  - Mode D: Enable Channel A Output until Programmed Cycle Count is reached, then disable all Channel A Output until the Counter Subsystem is reset.
  - Mode E: Same as Mode D, but pulse the Channel B Output programmed period when Channel A Output is disabled.
  - Mode F: When the Programmed Cycle Count is reached, automatically reset the Counter Subsystem Count and start for a over. Pulse the Channel B Output for a programmed period when the Count is reached.
- Selectable Stitch Option
- Selectable Latch-On and Repeat Cycle Options
- Three Time Ranges: 0-.999 Second, 0-9.99 Second, and 0-99.9 Second
- External Count Reset Input for the Counter

## And features Common to Both...

- Four Program storage capacity in Non-Volatile Memory
- No Battery Back-Up required
- Sixteen Character by two line LCD Display Window
- On Screen Status Line
- Input and Output Test Routines
- Program Security (Access Code)
- 115 VAC and 24 VDC Outputs available
- Optional Cable Assemblies and Plug-in Connector Kits for Inputs and Outputs

**A functional PRO SERIES TIMER or TIMER/COUNTER installation should include at least one each of the following items:**

<p><b>PRO SERIES CONTROLLER</b></p>	<p>45-20-01 Pro Series Timer, DC Output          45-20-02 Pro Series Timer, AC Output          45-20-11 Pro Series Timer/Counter, DC Output          Pro Series Timer/Counter, AC Output</p>
<p><b>DRIVER BOARD(S)</b>          (One 95-06-38 DC or 95-07-24 AC Driver Board is included with the controller)</p>	<p>95-06-38 Driver Board, DC          95-02-19 Driver Board, H/S Actuator</p>
<p><b>TRIGGER INPUT DEVICE</b>          (Also Timer/Counter Reset Device, if Required)</p>	<p>Photo Sensors and other electronic sensing devices, current sinking (open collector)          Mechanical Limit Switches          95-01-93 Reflective Photo Sensor Assembly          95-01-94 Photo Sensor Receiver and Transmitter Assembly          95-01-91 Reflector Photo Sensor Assembly, H/S          Fiber Optic Photo Sensor Assembly, H/S</p>
<p><b>ONE OR MORE SOLENOIDS OR VALVES</b>          (Appropriate Driver Boards Required)</p>	<p>40-40-02 Applicator Valve Actuator (Requires 95-02-19 Driver Board)          40-40-12 Applicator Valve Actuator (Requires 95-06-38 Driver Board)          40-01-XX Electric Valve, AC (Requires 95-07-24 Driver Board)          40-0X-50 Air Electric Control Assemblies, AC or DC (Requires 95-07-24 AC or 95-06-38 DC Driver Board)</p>
<p><b>CONNECTORS AND CONNECTING CABLES AS REQUIRED</b> (optional)</p>	<p>78-00-86 Output Kit with DIN Connector          95-02-XX Cable Assemblies for Speed Tracker          95-02-40 9-wire Quick Connect Kit          95-02-43 9-wire Plug Kit          95-02-41 3-wire Quick Connect Kit          3-wire Plug Kit</p>

**For more information,  
 Contact Your Local VanSco Distributor...  
 ...or PHONE, FAX, or WRITE:**



**2652 Lashbrook Avenue, South El Monte  
 California 91733  
 (818)448-7611 FAX (818)448-0221**